

Sludge delivery line

ZX 150 / 6

Working Pressure 100 bar

Possible operations:

Especially suitable for paste-like, abrasive media with high dry matter content at high pressures in the delivery line.

Advantages:

- Putzmeister high pressure delivery line with favourably-priced quickaction coupling system, wellproven in 24 hour continuous operation for stationary or temporarily laid pipe lines in sewerage treatment works, paper mills, etc.
- ZX screw couplings are simple and quick to assemble
- The ZX coupling system guarantees an absolutely leak-proof delivery line
- The delivery line centred by the coupling system is straight and rigid

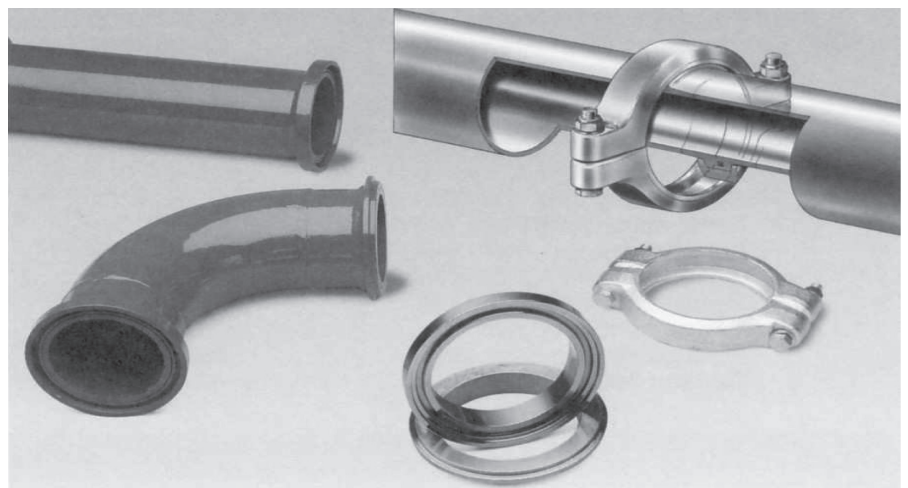

Explanations:

Every ZX line always commences with a ZXV connection piece and finishes with a ZXM one.

Technical dimensions:

Pipe:

1. Outside diameter	168.3 mm
2. Inside diameter	151.0 mm
3. Wall thickness	8.8 mm

Coupling:

4. Width	342.0 mm
5. Fitting dimensions	60.0 mm

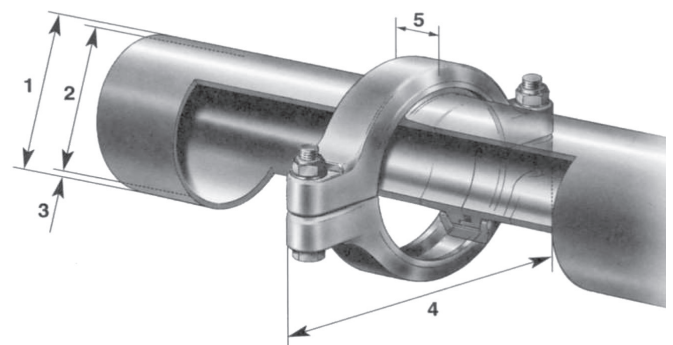

Couplings / Seals

Designation		Part-Nr.	Approx. Weight unit/kg	Partgroup/disc. level
Screw coupling	ZX-S 130 bar dyn.	241291005	7.8	5
Seal	170.8 x 7.0	069042009	0.025	5
Seal	170.8 x 7.0 Viton	233722003	0.042	5

Delivery pipes / Welding rings

Designation		Part-Nr.	Approx. Weight unit/kg	Partgroup/disc. level
Delivery pipe	500 mm lg	243120006	20.0	5
Delivery pipe	1000 mm lg	243121005	42.0	5
Delivery pipe	2000 mm lg	243122004	76.0	5
Delivery pipe	3000 mm lg	243123003	on request	5
Delivery pipe	6000 mm lg	243124002	230.0	5
Raw pipe approx.	approx. 6000 mm lg	004614007	36.0	5
Welding ring	ZXV	244032009	3.0	5
Welding ring	ZXM	244029009	3.3	5

Delivery pipe elbows

Designation		Part-Nr.	Approx. Weight unit/kg	Partgroup/disc. level
Delivery pipe elbow	15°, r = 305 HD	243128008	on request	5
Delivery pipe elbow	30°, r = 305 HD	243127009	13.0	5
Delivery pipe elbow	45°, r = 305 HD	243126000	13.5	5
Delivery pipe elbow	90°, r = 305 HD	243125001	20.5	5

Large radius elbows

Designation		Part-Nr.	Approx. Weight unit/kg	Partgroup/disc. level
Large radius elbow	15°, r = 1000 HD	243392009	on request	5
Large radius elbow	30°, r = 1000 HD	243393008	on request	5
Large radius elbow	45°, r = 1000 HD	243394007	28.0	5
Large radius elbow	90°, r = 1000 HD	243395006	70.0	5

Delivery hoses, fixed on both sides

Designation		Part-Nr.	Approx. Weight unit/kg	Partgroup/disc. level
Delivery hose	ZX 150, 3000 mm lg, 85 bar stat.	404816	65.0	7
Delivery hose	ZX 150, 4000 mm lg, 85 bar stat.	409909	36.0	7

Delivery hoses and End hoses are available in various lengths: 1 m – 40 m

Cleaning accessories

Designation		Part-Nr.	Approx. Weight unit/kg	Partgroup/disc. level
Sponge ball	D 175 - medium	026650007	0.502	7
Sponge scraper	NW 150	253955009	2.7	5
Cleaning connection	ZXV 150	259824008	8.4	5
Sponge ball hard	D 150 - hard	406379	0.87	7

Other accessories

Designation		Part-Nr.	Approx. Weight unit/kg	Partgroup/disc. level
Forked pipe	1000 mm lg	259825007	130.0	5
T-delivery pipe	1000 mm lg	258940006	70.0	5
Y-delivery pipe	1000 mm lg	263889000	93.0	5
Pressure gauge	0 – 100 bar analog	273840000	on request	on request
Pipe attachment	complete	265400005	on request	on request
Lid	ZXV 200/8	258527005	5.0	5
Lid	ZXM 200/8	277405001	5.75	5

Sludge delivery line, ZX 150 / 6, 100 m long, consisting of:

Quantity	Designation	Part-Nr.	Approx. Weight unit/kg	
40	Screw coupling ZX-S	241291005	7.8	
40	Seal 170.0 x 7.0	069042009	0.025	
2	Delivery pipe 2000 mm lg	243122004	76.0	
12	Delivery pipe 3000 mm lg	243123003	on request	
10	Delivery pipe 6000 mm lg	243124002	230.0	
2	Welding ring ZXV	244032009	3.0	
2	Welding ring ZXM	244029009	3.3	
1	Large radius elbow 15°, r=1000 ND	243392009	on request	
1	Large radius elbow 30°, r=1000 ND	243393008	on request	
2	Large radius elbow 45°, r=1000 ND	243394007	28.0	
5	Large radius elbow 90°, r=1000 ND	243395006	70.0	
1	Delivery hose ZX 150,3000 lg	404816	65.0	
5	Sponge ball average D 175	026650007	0.502	
1	Cleaning scraper NW 150	253955009	2.7	
1	Cleaning connection ZXV 150	259824008	8.4	
1	T-delivery pipe 1000 mm lg	258940006	70.0	
22	Pipe attachment cpl.	265400005	on request	

Sludge delivery line, ZX 150 / 6, 200 m long, consisting of:

Quantity	Designation	Part-Nr.	Approx. Weight unit/kg	
70	Screw coupling ZX-S	241291005	7.8	
70	Seal 140.0 x 6.0	069042009	0.025	
4	Delivery pipe 2000 mm lg	243122004	76.0	
24	Delivery pipe 3000 mm lg	243123003	on request	
20	Delivery pipe 6000 mm lg	243124002	230.0	
4	Welding ring ZXV	244032009	3.0	
4	Welding ring ZXM	244029009	3.3	
2	Large radius elbow 15°, r=1000 ND	243392009	on request	
2	Large radius elbow 30°, r=1000 ND	243393008	on request	
4	Large radius elbow 45°, r=1000 ND	243394007	28.0	
8	Large radius elbow 90°, r=1000 ND	243395006	70.0	
1	Delivery hose ZX 125, 3100 lg	404816	65.0	
10	Sponge ball average D 150	026650007	0.502	
3	Sponge scraper D 150 x 180	253955009	2.7	
1	Cleaning connection ZXV 125	259824008	8.4	
1	T-delivery pipe 1000 mm lg	258940006	70.0	
44	Pipe attachment cpl.	265400005	on request	